



INSTALLATION INSTRUCTIONS FOR BELTRONICS AND ESCORT RADAR DETECTORS

Your rear view mirror has minimal clearance between the back side of the mirror and the mirror stem. It is very important that this mount is installed correctly to ensure mirror adjustability is retained.
PLEASE READ THESE INSTRUCTIONS THOROUGHLY BEFORE INSTALLING THIS MOUNT

NOTE: For illustration purposes, the mount and rear view mirror shown in these instructions may look slightly different than YOUR mount and rear view mirror.



Before installing this mount on your mirror observe how the spring clip functions. **When used properly, the spring clip avoids putting excessive pressure on the mirror when installing and removing the radar detector (RD).** To release tension from the spring clip, simply squeeze the tab and the back side of the mount together. This will lower the bottom portion of the spring clip allowing you to slide the RD on and off the mount. Push the Release button and slide the RD onto the Spring Clip until you hear it lock into position, then release both the Tab and Release Button. Install and remove the RD a few times before installing the mount on your mirror. **Once the installation is complete, the spring clip allows you to access the buttons on top of the RD while still having the RD installed to sit as close to the bottom of the rear-view mirror as possible.** By gently pushing down on the RD the spring clip is designed to flex downward allowing you to push desired buttons, then it will spring back into its original position when you take your finger away. This can also be useful to access the release button.

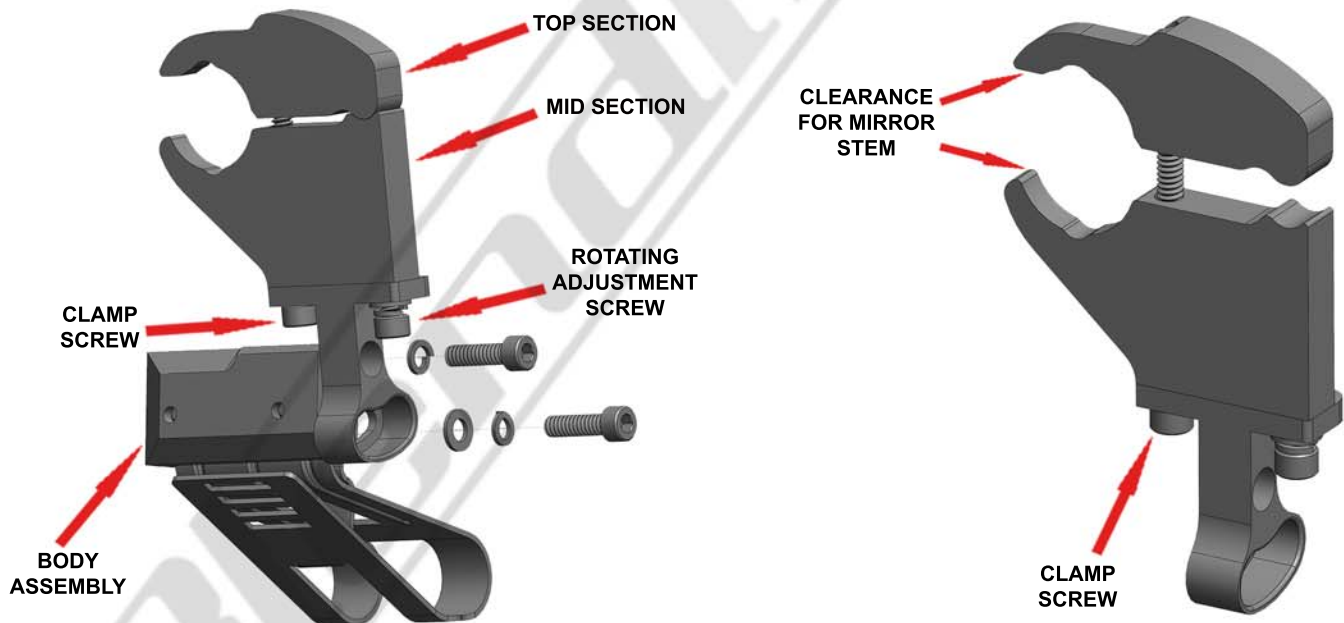

STEP 1 - The BODY ASSEMBLY must be removed to gain access to the CLAMP SCREW. Remove the two socket head screws as shown above. Be sure to remove the lock washer with the top screw along with the lock washer and flat washer with the bottom screw.

STEP 2 - Loosen the CLAMP SCREW so there is enough clearance between the TOP and MID SECTIONS to slide over the mirror stem.

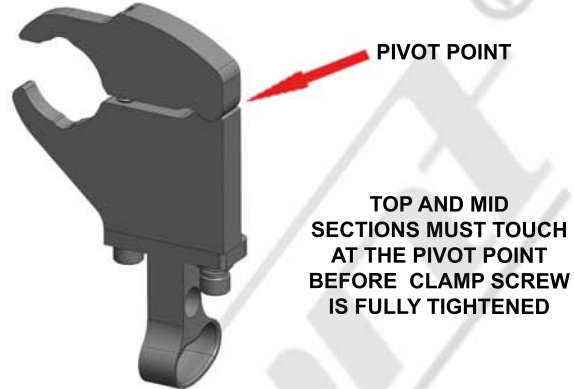

STEP 3 - While sitting in the passenger seat, place the mount over the mirror stem. Tighten the CLAMP SCREW until the mount starts to clamp onto the mirror stem. Position the mount as far forward as it will go and parallel to the bottom of the mirror before fully tightening.

STEP 4 - MAKE SURE THE TOP AND MID SECTIONS ARE TOUCHING AT THE PIVOT POINT. If you can not get them to touch at the pivot point, you have an **incompatible mirror type for this mount.**

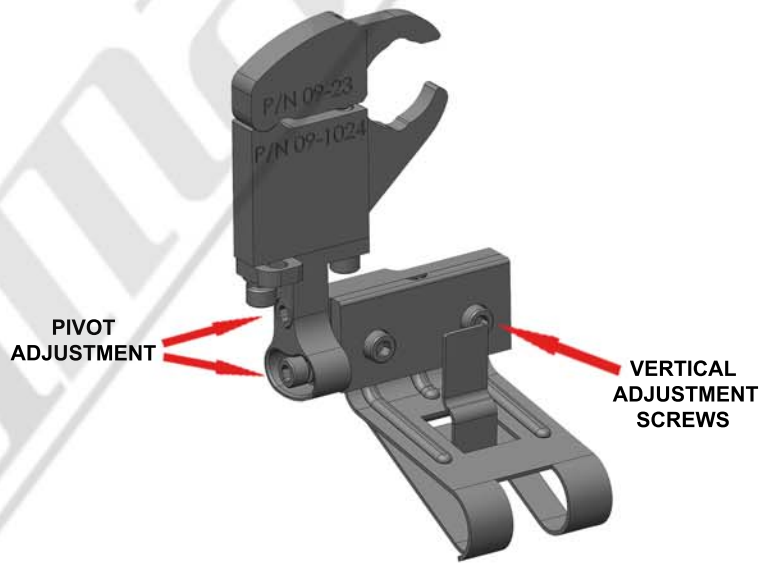
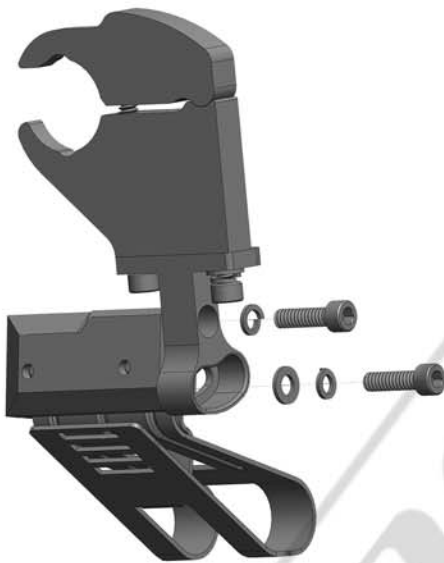

STEP 5 - Reinstall the BODY ASSEMBLY. Be sure to include the lock washer with the top socket head screw and the lock and flat washer with the bottom socket head screw as shown above. NOTE: there are extra lock and flat washers included in the tool kit just in case you happen to misplace one.

STEP 6 - Install your radar detector onto the mount. Use the adjustments shown above to adjust the RD to your desired position. We recommend adjusting the RD as close to the bottom of your mirror as you can. Be sure to tighten all adjustment screws after the adjustments are made.

CAUTION

DO NOT use this mount if it interferes with the adjustability or the operation of your rear view mirror in any way.

DO NOT use this mount if the radar detector creates an unsafe viewing obstruction.

DO NOT ATTEMPT TO MODIFY THIS PRODUCT. Consult the manufacturer for assistance.

All BlendMount products are accompanied with detailed installation instructions and adjustment tips. You are encouraged to contact customerservice@blendmount.com or call J28 Design at 1-888-497-8388 for further assistance.

Check the BlendMount Forum for installation tips and some vehicle specific installs.
www.blendmount.com

Your feedback is very important to us. Please email any questions or comments you have to customerservice@blendmount.com